

PRODUCT APPLICATION

Process Industry - Tankage Rationalization

Storage tankage is not typically an issue that generates excitement among plant engineers. However, when process plants are designed and operated it is very important that consideration be given to how tankage affects long-term production. In any process plant, there exists an optimal balance between tankage and its associated capital, maintenance, and inventory costs/taxes versus the ultimate improvement in long-term production capability.

Tankage Costs/Benefits

In virtually every plant, operations would like to have as much tankage as possible. Extra tankage provides operational flexibility – especially during upsets. However, extra tankage costs additional money to build and maintain, and it consumes working capital in the form of inventory. The proper amount of storage capacity is clearly a balancing act between these differing objectives.

Tankage Significantly Affects Plant Availability

The amount of storage tankage affects the long-term production capability of most process plants in ways that would surprise many process engineers. Even in a very simple system, as shown here, system availability plateaus as tankage size increases. Clearly, there is an optimal storage size that balances increases in availability versus costs to construct or maintain storage.

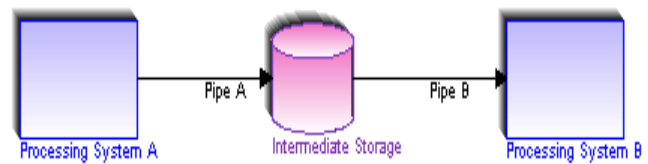

Historically Tankage was Determined with “Rules of Thumb”

Until recently, there was very little science involved in determining optimal storage requirements and was usually based on rules of thumb. As one senior engineer at a large refinery said, “Can you give me a technique that can help provide a basis to determine how much crude tankage we need so that we don’t have to get around the table and just make a wild guess?” Fortunately, the answer is yes.

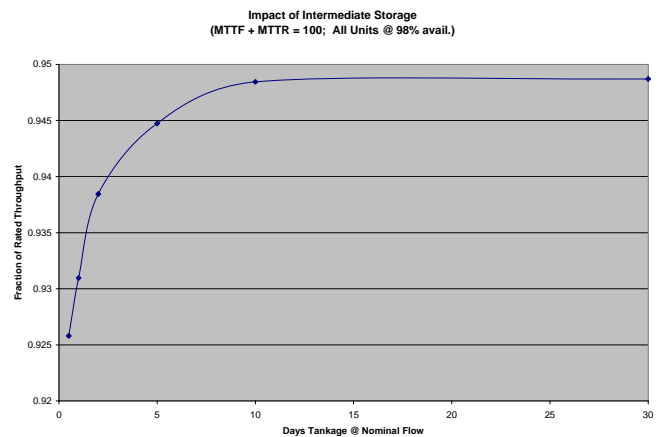

Calculating the “Optimal” Tankage Requirements

Clockwork’s technology allows engineers the ability to determine the optimal tankage requirements based on a Monte-Carlo analysis combined with various optimization techniques. The analysis takes into account average unit availabilities and the failure characteristics of each process unit. Plant operations are simulated over a time period of many years. The optimizer adjusts each tankage size to balance the additional contributions to the product pool against the cost to install or maintain the tank and inventory / tax considerations. The output of this analysis is the storage tankage size for each tank in the system.

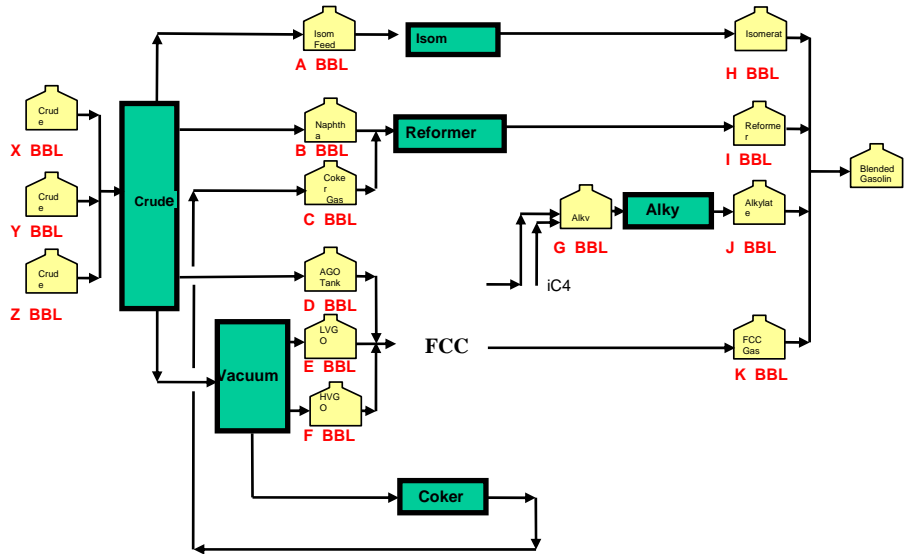

“Optimal” Tankage Size Varies as Unit Reliability Changes

The optimal amount of tankage is a strong function of:

- Unit availabilities
- How process units are interconnected
- Plant economics

The associated graph shows how the optimal storage size changes as unit availabilities change. Thus, as improvements are made in unit reliabilities, it is certainly possible to retire excess tankage.

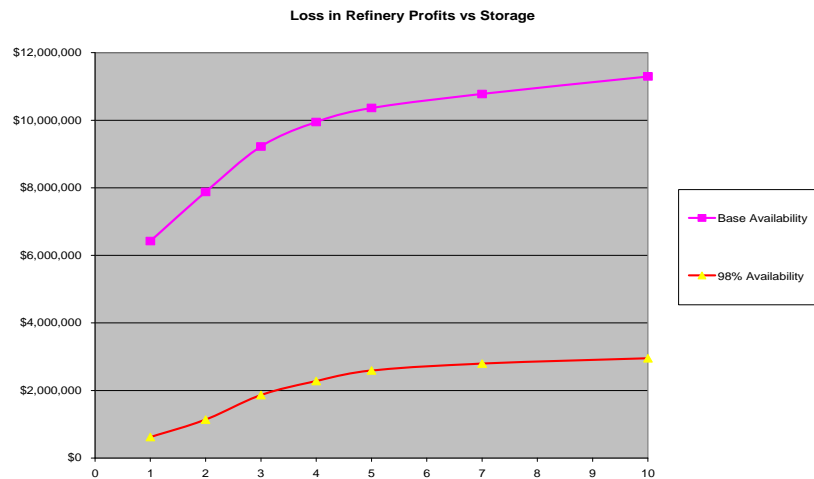

Contact:

Email: info@clockwork-solutions.com

Website: www.clockwork-solutions.com