

PRODUCT APPLICATION

Process Industry Solutions

Clockwork Solutions provides designers and operators of refining, hydrocarbon, and chemical plants with decision tools and technology to maximize the value of their assets and manage them more cost-effectively. Clockwork's technology provides professionals in the process industries with answers to such questions as:

- Which process unit(s) should I spend capital on to increase the long-term production capability of the plant? What is the optimal allocation of that capital?
- What is the optimal turnaround timing for this process unit? What equipment should be included in this turnaround or can be delayed to a latter time?
- For a given process unit, if I spend capital to increase availability, what is my ROI? Am I gold-plating this unit unnecessarily?
- Where can tankage be eliminated without decreasing the long-term production capability of the plant?

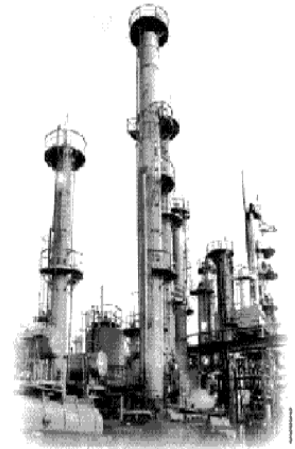

Plant-Wide “Availability Throughput” Optimization

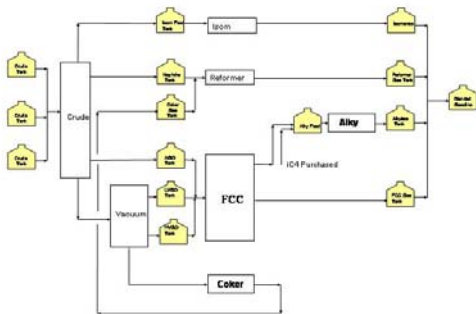

Clockwork's technology can answer the question, “Where should I spend my next capital or maintenance dollar to increase long-term production capability?”

Plant-wide availability models are constructed and a general purpose optimization run to determine optimal unit availabilities, long-term throughput, and optimal unit capital costs. The optimization selects unit availabilities and calculates the corresponding system availability, the NPV of increased production, and the capital costs to achieve those availabilities. The objective function maximizes the difference between the production increase and the capital investment necessary to achieve that production increase.

Run-Length Optimization

Clockwork technology can be used to determine what equipment should be included in this turnaround and which equipment can be postponed based on a risk analysis. These techniques have also proved valuable in determining the optimal spacing between turnarounds.

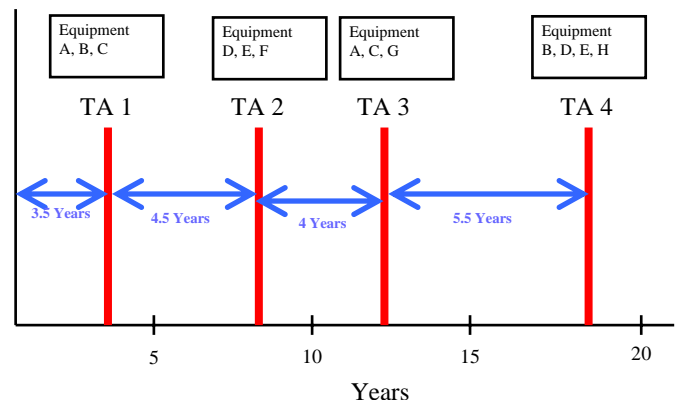

Unit Availability Optimization

In any process unit, there always exists an optimal balance between additional capital investments in equipment and achieving an ultimate improvement in unit availability. Even for an experienced engineer, it is not always intuitive to predict how changes in equipment reliability will affect unit availability due to equipment interactions, sparing philosophies, etc. Clockwork's technology allows designers the information to be able to make accurate long-term cost/benefit decisions.

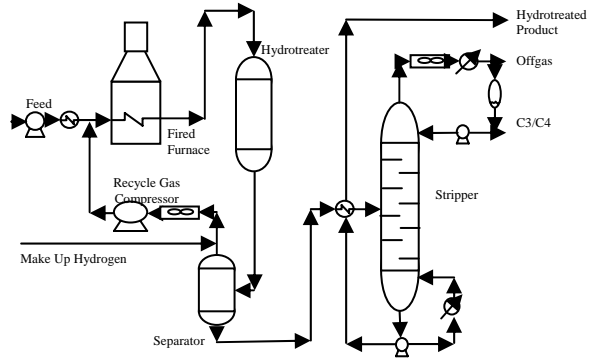

Tankage Rationalization/Reduction

Clockwork technology can determine the optimal amount of intermediate storage for each tank in a complex plant. This allows enough tankage for ordinary process fluctuations without the undue working capital costs associated with excess storage. Some refiners have recently used these techniques to assess which tanks should be maintained and which should be retired from service.

Life Cycle Asset Management Technology

Life cycle asset management technology is a combination of Monte-Carlo discrete event simulation technology, various optimization technologies, along with, of course, a healthy dose of process know-how. It is largely a probability-based technique that allows a plant to assess the risk in a particular design or maintenance strategy.

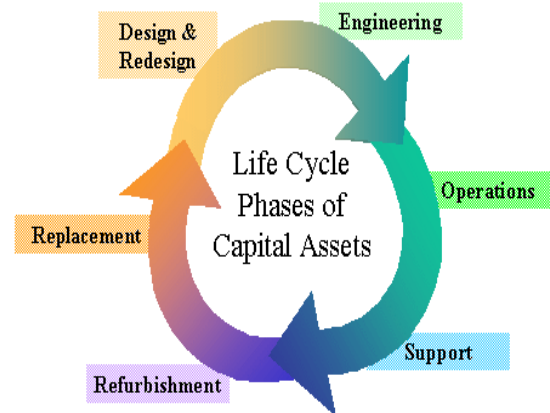

Contact:

Email: info@clockwork-solutions.com

Website: www.clockwork-solutions.com